

Vapour generation at a UV/TiO₂ photocatalysis reaction device for determination and speciation of mercury by AFS and HPLC-AFS†

Yanmin Yin,^a Jing Liang,^a Limin Yang^a and Qiuquan Wang^{*ab}

Received 6th October 2006, Accepted 15th December 2006

First published as an Advance Article on the web 12th January 2007

DOI: 10.1039/b614555h

In this study we report a method for direct vapor generation of mercury species on nano TiO₂ under UV irradiation in the presence of a formic acid and sodium formate mixture as a hole scavenger. A novel designed UV/TiO₂ photocatalysis reaction device (UV/TiO₂ PCRCD) was used as an effective sample introduction unit and an interface for mercury species determination by atomic fluorescence spectrometry (AFS) and speciation by HPLC-AFS for the first time. The detection limits of 10, 20, 30 and 70 pg mL⁻¹ of mercury chloride, methylmercury chloride, ethylmercury chloride and phenylmercury chloride, respectively, were achieved by AFS using flow injection mode. Compared with the traditional KBH₄/NaOH-HCl system, UV/TiO₂ PCRCD is a superior alternative for online vapor generation of Hg species.

Introduction

Information concerning the concentration of trace elements, especially during speciation analysis, has increasing significance in terms of elucidating their corresponding environmental behavior and biological functions. Chemical vapour generation (CVG) acts as an effective sample introduction method for specific trace element determination using atomic spectrometry, easily achieving simultaneously matrix separation and greatly improved detection power. Mercury (Hg), a typical toxic and vapour generating element, can be effectively converted from its existing species into the so-called cold vapour state (Hg⁰) by reductants, such as hydroborate and/or SnCl₂,¹ and a low molecular weight acid (LMWA) under UV irradiation,² and can then swept by argon gas through a gas-liquid separator into an atomic fluorescence spectrometer (AFS) for determination.³⁻⁵ The hypothesis behind the process is that electrons transfer from atomic hydrogen and/or hydroboron intermediates or LMWA radicals, generated from the precursors, to Hg species.^{1,6,7} Here, we report an attractive alternative to obtain active electrons for online reduction of Hg species into Hg⁰, allowing a sensitive determination and speciation of Hg species in environmental and biological samples by AFS and HPLC-AFS, in which nano titanium dioxide (TiO₂) stabilized on the surface of a glass fibre was utilized to offer active electrons under UV irradiation, while formic acid (HCOOH)-sodium formate (HCOONa) buffer served as a hole scavenger.

When the size of a TiO₂ particle reaches nanometre levels, the successive energy bands may separate into valence bands (VB) and conduction bands (CB). If the particle is illuminated by a light with a wavelength shorter than 387 nm, in other words, the energy of the light is higher than the energy gap (normally 3.2 eV) between the CB and VB,⁸ an electron (e⁻) will be photogenerated and excited from VB to CB, while a positive hole (h⁺) is simultaneously generated at VB as shown in Fig. 1a. Utilizing the active h⁺ or e⁻ to oxidize organic pollutants or reduce heavy metal ions for degradation or the removal of pollutants from the environment has been reported.⁹⁻¹² However, the time for the oxidization and/or reduction is too long to be used for analytical purposes. Sophisticated experimental designs are obviously needed to accelerate the efficiency and the speed of oxidation and/or reduction of target analytes. The energy gap increases as the size of the nano TiO₂ particle decreases due to the quantum size effect, resulting in a greater reductive ability of the e⁻ at CB; moreover, the distance needed for the generated e⁻ at CB and h⁺ at VB to move from the bulk to the surface is greatly shortened, remarkably reducing the probability of recombination of the generated e⁻/h⁺ pairs in the bulk, and resulting in more generated e⁻ and h⁺ migrating to the surface of the nano TiO₂ particle. Furthermore, when an h⁺ scavenger is added in a reaction medium to prohibit the generated e⁻/h⁺ pair from rapid recombination, the remaining free e⁻ may serve as a reductant to reduce target analytes adsorbed on the surface of the nano TiO₂. Such a property has recently been applied to the reduction of hexavalent selenium (Se), prior to its hydride generation, by sodium tetrahydroborate and/or by flowing through an electrical flow-cell, as well as direct vapour generation of inorganic Se species for Se speciation analysis in our and Sun's research groups.¹³⁻¹⁵ Considering the strong reductive ability of e⁻ at CB (the reduction potential is -0.3 V at pH 0),¹⁶ Hg²⁺ can be spontaneously reduced to Hg⁰ ($\varphi_{\text{Hg}^{2+}/\text{Hg}^0}^0 = 0.85 \text{ V}$). Direct photocatalysis vapor generation of Hg species on nano TiO₂ under UV irradiation, followed by

^a Department of Chemistry & the MOE Key Laboratory of Analytical Sciences, Xiamen University, Xiamen 361005, China. E-mail: qqwang@xmu.edu.cn; Fax: +86 592 2181796; Tel: +86 592 2181796

^b State Key Laboratory of Marine Environmental Science, Xiamen University, Xiamen 361005, China

† Electronic supplementary information (ESI) available: Fig. S1, SEM image of nano TiO₂ film coated on the glass fibre; Fig. S2, effect of h⁺ scavenger on the vapor generation efficiency of Hg species. See DOI: 10.1039/b614555h

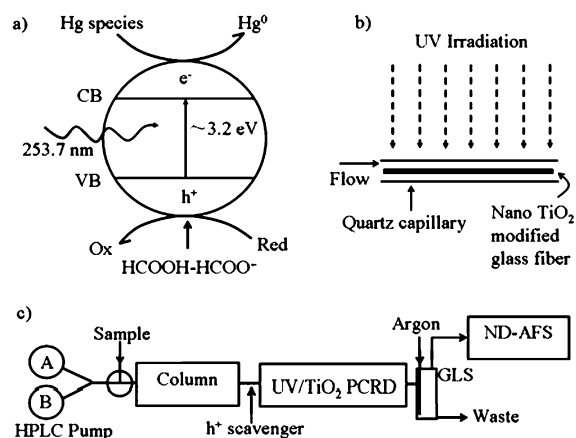

Fig. 1 Schematic diagram of (a) reduction of Hg species on nanoTiO₂ particle; (b) UV/TiO₂ PCRD; and (c) HPLC-(UV/TiO₂ PCRD)-AFS.

on-line AFS determination, is now proposed in this study for the first time, to our knowledge.

Experimental

Nano TiO₂ film stabilized on the surface of a glass fibre of 0.3 mm O.D. was prepared by dipping the glass fibre into and pulling it out of a sol prepared by conventional sol-gel methods using butyl titanate and ethanol (pH 3.5, adjusted by diluted HNO₃), and drying at 80 °C for 30 minutes in an electric stove and then calcining at a gradually increasing temperature (1.5 °C min⁻¹ to 450 °C) before keeping constant for 1 hour.¹³ About 6 nm anatase TiO₂ was obtained in the film (Fig. S1, ESI[†]). Such a nano TiO₂ modified glass fibre was inserted and fixed centrally into a quartz capillary 150 mm in length × 0.8 mm I.D. and irradiated by a 40 W low pressure Hg lamp of 130 mm in length × 25 mm O.D. so as to get the UV/TiO₂ photocatalysis reaction device (UV/TiO₂ PCRD) (schematically shown in Fig. 1b). Sample solution and HPLC effluent can flow through the space between the glass fibre and the wall of the capillary for online reduction of Hg species. Hg determination was performed on a non-dispersive atomic fluorescence spectrometer (Beijing Rayleigh Analytical Instrument Corporation) equipped with a high performance Hg hollow cathode lamp (253.7 nm, Beijing Institute of Vacuum Electronics Research, China).⁵ All reagents used were at least of analytical agent grade and 18 MΩ Milli-Q water (Millipore, Bedford, MA, US) was used throughout this study. Mercury chloride was obtained from Shanghai Chemicals, and methylmercury chloride (MMC), ethylmercury chloride (EMC) and phenylmercury chloride (PMC) were purchased from Dr Ehrenstorfer GmbH. All Hg species separations were performed on a Shim-Pack VP-ODS column (150 × 4.6 mm I.D.) using a mixture of acetonitrile and water (65 : 35) containing 1.5 mmol L⁻¹ ammonium pyrrolidine dithiocarbamate (APDC) (pH 5.5 buffered by acetic acid–ammonium acetate) as a mobile phase¹⁷ performed on a Shimadzu LC-2010A (Kyoto, Japan). Lake sediment and seafood samples were pretreated as described previously^{18,19} before HPLC-(UV/TiO₂ PCRD)-AFS. Briefly, for seafood samples, 3 mL

of 5 mol L⁻¹ hydrochloric acid was added to 0.2 g of the certified reference material BCR 463 (tuna fish) or 1.0 g of real sample in a centrifuge tube. Then the mixture was placed in an ultrasonic bath for about 10 min. After extraction, the suspension was centrifuged at 3500 rpm for 10 min, and the supernatant was added to another centrifuge tube. The residue was extracted again as described above. The two supernatant portions were combined, neutralized with 10 mol L⁻¹ NaOH, and then diluted to volume with pure water (pH 2.0–5.0), and finally filtered through a 0.45 μm filter and injected directly into the HPLC-(UV/TiO₂ PCRD)-AFS system for speciation analysis. For sediment samples, briefly, 1.0 g sediment sample and 25% (m/v) KOH (in methanol) were added in each 50 mL centrifuge tube. This mixture was sonicated and shaken mechanically and then CH₂Cl₂ and concentrated HCl were added to the tube in sequence, shaking to extract organic mercury into the CH₂Cl₂ phase, while the inorganic Hg remained in the water phase. After centrifuging at 3500 rpm for about 10 min, the CH₂Cl₂ phase was transferred into a 7 mL centrifuge tube. 1 mL of 10 mM sodium thiosulfate solution was added for stripping organic Hg species by vigorously shaking for 45 min. After filtering through a 0.45 μm filter, the water phase was injected directly into the (UV/TiO₂ PCRD)-AFS system for speciation analysis.

Results and discussion

Performance of UV/TiO₂ PCRD-AFS

As shown in Fig. 1b, the effectiveness of the designed UV/TiO₂ PCRD for online reduction of Hg species was demonstrated by a flow injection system with AFS detection. Based on the above discussion, the h⁺ scavenger used plays a key role in obtaining free e⁻. Therefore, 0.1% (m/v) β-cyclodextrin and 0.5 mol L⁻¹ of glycerol, oxalic acid, hydroquinone, tartaric acid, potassium sodium tartrate and formic acid–sodium formate (HCOOH–HCOONa) were used, individually, as h⁺ scavengers at a flow rate of 2.5 mL min⁻¹. Results obtained (Fig. S2, ESI[†]) indicated that HCOOH–HCOONa is the most effective h⁺ scavenger, followed in order by potassium sodium tartrate > hydroquinone > tartaric acid > oxalic acid > glycerol ~ β-cyclodextrin, in the case of Hg²⁺, MMC and EMC. It should be noted that the atomic fluorescent signals for Hg species could still be detected when no organic electron donors (scavengers) other than H₂O were in the reaction medium. This could be explained because H₂O can also be oxidized by the h⁺ (its redox potential is 2.9 V at pH 0).¹⁶ Compared with H₂O ($\varphi_{\text{O}_2/\text{H}_2\text{O}}^0 = 1.23 \text{ V}$) HCOOH–HCOONa, for example, is much more effective in scavenging the h⁺ ($\varphi_{\text{CO}_2/\text{HCOOH}}^0 = -0.2 \text{ V}$; $\varphi_{\text{CO}_3^{2-}/\text{HCOO}^-}^0 = -0.95 \text{ V}$); moreover, the acidity of the HCOOH–HCOONa used is pH 3.1, resulting in HCOOH being the main form existing (80.8%). It has a stronger tendency to adsorb onto the TiO₂ surface,²⁰ leading to HCOOH not only being an effective h⁺ scavenger but also effective in preventing O₂, which is a very strong e⁻ acceptor ($\varphi_{\text{O}_2/\text{H}_2\text{O}_2}^0 = 0.68 \text{ V}$), from forming due to the possible oxidation of H₂O in the reaction medium. Investigation of the effects of the concentrations of HCOOH

and HCOONa on the vapour generation efficiency of Hg species indicated that 2.7 M HCOOH and 1.5 M HCOONa mixed solution is optimum for all the Hg species studied. The signal intensity of Hg species increases along with the increase of exposure time from 1 s to 4 s, but reaches a plateau after 4 s, indicating that the cold vapor generation of Hg species is fast. A comparison of this proposed UV/TiO₂ PCRD with the most frequently used KBH₄/NaOH-HCl system for the vapour generation of Hg species,^{1,3-5,21} followed by AFS detection, is shown in Fig. 2, indicating that the atomic fluorescent signal intensity of 100 ng mL⁻¹ MMC has been improved more than 3 times, and that of Hg²⁺ more than 1.3 times, and the relative vapor generation efficiencies of Hg²⁺ and MMC were 138 and 352%, respectively. The resulting detection limits (3σ) of Hg²⁺, MMC, EMC and PMC were 10, 20, 30 and 70 pg mL⁻¹, respectively. Obviously, UV/TiO₂ PCRD is more effective on the vapour generation of Hg species without obvious species discrimination. This phenomenon might be explained by the fact that the bond between carbon and Hg in organic Hg species could be broken under UV irradiation, which would lead to the organic Hg species being reduced as easily as Hg²⁺. Furthermore, the fluorescent signals of Hg²⁺ and MMC have also been observed when only UV irradiation was employed in the presence of HCOOH-HCOONa, although the signal intensities were relatively low (dot line in Fig. 2). This was also observed by Sturgeon *et al.*² and Hou *et al.*²²

Usually, conventional hydroborate CVG media suffer serious interferences from many coexisting elements,^{1,23-27} and can be remarkably avoided or reduced by sophisticated optimization of experimental conditions.²⁸ The interference experiments with foreign ions were done under the optimum conditions in this study to clarify the tolerance of the proposed UV/TiO₂ PCRD. Results listed in Table 1 indicated that the recoveries of Hg²⁺ are from 63.0 to 120%. Most anions tested

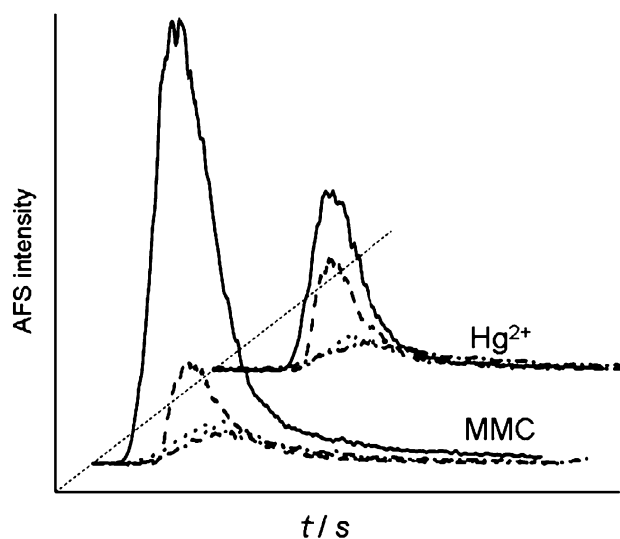

Fig. 2 Comparison of UV/TiO₂ PCRD with KBH₄/NaOH-HCl system for the vapour generation efficiency of Hg²⁺ and MMC. The concentrations of Hg²⁺ and MMC are 5 ng each, respectively. Solid line: UV/TiO₂ PCRD-HCOOH-HCOONa; dash line: KBH₄/NaOH-HCl; dot line: UV-HCOOH-HCOONa; dash dot line: UV/TiO₂ PCRD-H₂O.

Table 1 Interference of foreign ions^a

| Ion | UV/TiO ₂ PCRD system | | Conventional chemical vapour generation (KBH ₄ or NaBH ₄ /NaOH-HCl or SnCl ₂) | | Ref. |
|---|---------------------------------|-------------------------|---|-------------------------|------|
| | Conc. added ^b | Rec. of Hg ^c | Conc. added ^b | Rec. of Hg ^c | |
| Cl ⁻ | 1000 | 98.0 | 20% m/v | 25 | 23 |
| Br ⁻ | 1000 | 95.2 | | | |
| I ⁻ | 1000 | 82.4 | 100 ng mL ⁻¹ | 55 | 24 |
| NO ₂ ⁻ | 100 | 99.5 | 10% m/v | 90 | 25 |
| H ₂ PO ₄ ⁻ | 100 | 99.5 | | | |
| SO ₄ ²⁻ | 1000 | 81.7 | | | |
| Ag(i) | 0.1 | 94.3 | [Ag]/[Hg] = 25 | 90 | 26 |
| Pt(iii) | 0.03 | 80.9 | | | |
| As(v) | 100 | 101 | | | |
| Al(iii) | 200 | 96.2 | | | |
| Ba(ii) | 1000 | 108 | | | |
| Bi(iii) | 10 | 84.4 | | | |
| Ca(ii) | 1000 | 93.7 | | | |
| Cd(ii) | 10 | 97.3 | | | |
| Co(ii) | 10 | 112 | | | |
| Cu(ii) | 0.5 | 103 | 100 mg L ⁻¹ | NSI ^d | 28 |
| Fe(ii) | 1000 | 105 | 100 mg L ⁻¹ | NSI ^d | 28 |
| Fe(iii) | 5 | 98.8 | 100 mg L ⁻¹ | NSI ^d | 28 |
| Ga(iii) | 50 | 102 | | | |
| Ge(iv) | 5 | 95.4 | | | |
| In(iii) | 200 | 115 | | | |
| La(iii) | 100 | 86.7 | | | |
| Ni(ii) | 10 | 93.5 | 100 mg L ⁻¹ | NSI ^d | 28 |
| Pb(ii) | 10 | 87.9 | 100 mg L ⁻¹ | NSI ^d | 28 |
| Sb(v) | 10 | 104 | | | |
| Sc(iii) | 10 | 120 | | | |
| Se(iv) | 0.1 | 94.8 | [Se]/[Hg] = 50 | 90 | 26 |
| Sn(iv) | 0.1 | 94.8 | | | |
| Te(vi) | 0.1 | 63.0 | | | |
| Ti(iii) | 10 | 87.6 | | | |
| Zn(ii) | 10 | 93.3 | A mixture of Ag, Al, B, Bi, Ca, Cd, Co, Cr, Cu, Fe, Ga, In, K, Li, Mg, Mn, Na, Ni, Pb, Sr, Tl and Zn of 50 μg mL ⁻¹ each | 13 | 27 |

^a 20 μL 100 ng mL⁻¹ Hg²⁺ was used. ^b Concentration added (μg mL⁻¹). ^c Recovery of Hg²⁺ (%), the RSD of 5 replicate runs was less than 3%. ^d NSI denotes not significant interference.

do not interfere with the vapour generation of Hg²⁺, except that I⁻ (recovery of Hg²⁺, 82.4%) and SO₄²⁻ (81.7%) slightly suppresses the signal. Most cations tested, for example, Fe(iii), Ni(ii) and Cu(ii), at the concentrations added, do not interfere in the vapour generation of Hg²⁺. Conversely, the existence of Ba(ii) (108%), Co(ii) (112%), In(iii) (115%) and Sc(iii) (120%) show enhancement effects, while Te(vi) (63.0%) seriously suppresses the Hg²⁺ signal.

The stability of nano TiO₂ film modified on the surface of the glass fibre used was tested by 11 replicate sample injections of Hg species during one experiment and after the nano TiO₂ modified glass fibre was used for more than one year, the relative standard deviation (RSD) of the obtained AFS signal intensities of same concentration of all the Hg species studied was less than 3% and 6%, respectively. Moreover, the signal

Table 2 Method validation and sample analysis ($n = 5$)

| Sample | Certified value/ $\mu\text{g g}^{-1}$ | | Determined value/ ng g^{-1} | | | Spike amount/ ng | | Spike recovery (%) | |
|------------------------------|---------------------------------------|-----------------------------|--------------------------------------|------------------------------|----------------------------|---------------------------|------------------|--------------------|------------------|
| | Total Hg | MMC ^a | Total Hg | MMC ^a | Hg ²⁺ | MMC | Hg ²⁺ | MMC | Hg ²⁺ |
| BCR 463 | 2.85 | 3.04 | 3.09 \pm 0.07 ^b | 2.93 \pm 0.14 ^b | ND ^c | 600 | | 98.1 | |
| BCR 580 | 132 \pm 3 | 75.5 \pm 3.7 ^d | 141 \pm 3 ^b | 70.2 \pm 1.5 | 134 \pm 2.7 ^b | 70 | | 92.1 | |
| <i>Ostrea titan</i> | | | 697 \pm 24 | 255 \pm 9.1 | 279 \pm 13.9 | 200 | 200 | 98.1 | 95.7 |
| <i>Haliotis diversicolor</i> | | | 189 \pm 7.1 | 153 \pm 6.6 | ND ^c | 200 | | 96.9 | |
| <i>Venerupis variegata</i> | | | 432 \pm 17.8 | 186 \pm 6.7 | 201 \pm 14.7 | 200 | 200 | 104.2 | 96.1 |

^a as CH₃Hg⁺. ^b $\mu\text{g g}^{-1}$. ^c ND, not detected. ^d ng g^{-1} .

intensity of Hg species did not fluctuate, even after dipping the glass fibre into *aqua regia* for 24 hours, indicating that the nano TiO₂ film on the glass fibre was sufficient stable for analytical purposes.

Hg speciation by HPLC-(UV/TiO₂ PCRD)-AFS

UV/TiO₂ PCRD was used as an interface to couple HPLC and AFS for Hg speciation (Fig. 1c). It should be mentioned that acetonitrile and APDC in the mobile phase slightly influenced the vapour generation of Hg species, resulting, respectively, in 4.3 and 14.6% decreases for Hg²⁺, and 3.6 and 9.8% for MMC. A typical chromatogram of an Hg²⁺, MMC, EMC and PMC mixed solution of 5 ng each is shown in Fig. 3a. BCR standard reference materials 463 (tuna fish) and 580 (estuarine sediment) were used for method validation. Results determined for total Hg and MMC are well in accordance with the certified values (Table 2). Moreover, the proposed HPLC-(UV/TiO₂ PCRD)-AFS system was applied to Hg speciation of a polluted lake sediment and seafood samples (*Ostrea titan*, *Haliotis diversicolor* and *Venerupis variegata*) collected on Xiamen Island and from the coast of the Island, in the south-eastern part of China, showing that both Hg²⁺ and MMC contamination could be found in the samples (Table 2 and Fig. 3c–e).

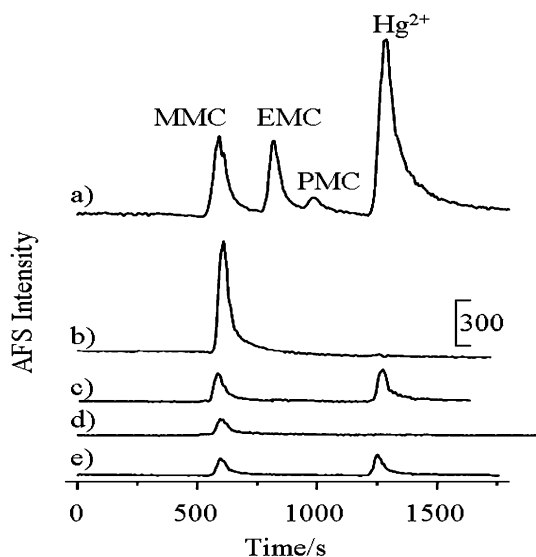

Fig. 3 Chromatograms of (a) Hg²⁺, MMC, EMC and PMC mixed solution of 5 ng each; (b) BCR 463 tuna fish; (c) *Ostrea titan*; (d) *Haliotis diversicolor*; (e) *Venerupis variegata*.

In summary, electrons at CB generated by UV light (253.7 nm) irradiation on the surface of nano TiO₂, which was stabilized on the surface of a glass fibre in the novelly designed UV/TiO₂ PCRD, have the reducing ability for the vapour generation of Hg species. UV/TiO₂ PCRD can be used not only as a sample introduction unit for Hg determination by AFS, but also as an online interface between HPLC and AFS for Hg speciation. Compared with the most frequently used KBH₄/NaOH–HCl system, UV/TiO₂ PCRD is obviously a superior alternative for the vapour generation of Hg species. Furthermore, it should be expected that the redox ability of UV/TiO₂ PCRD will find applications in elemental determination and speciation, as well as metallomics studies,^{29,30} when reduction and/or oxidation pretreatment is required before various spectroscopic determinations, after suitable modifications.

Acknowledgements

This work was financially supported by the National Natural Science Foundation of China (Nos. 20535020 and 20475046) and the National Basic Research Program of China (Nos. 2003CCA00500 and 2003CD415001). We thank Prof. Benli Huang for his continuous encouragements and valuable discussion. Professor John Hodgkiss is thanked for his assistance with English. The loan of Shimadzu HPLC 2010A and Rayleigh AFS-610A is gratefully appreciated.

References

- J. Dedina and D. L. Tsalev, *Hydride Generation Atomic Absorption Spectrometry*, Wiley and Sons, New York, 1995.
- X. M. Guo, R. E. Sturgeon, Z. Mester and G. J. Gardner, *Anal. Chem.*, 2004, **76**, 2401.
- J. E. Sanchez Uria and A. Sanz-Medel, *Talanta*, 1998, **47**, 509.
- US EPA, *Method 1631, Revision E*, 2002.
- J. Liang, Q. Q. Wang and B. L. Huang, *Anal. Sci.*, 2004, **20**, 85.
- A. D'Ulivo, M. Onor and E. Pitzalis, *Anal. Chem.*, 2004, **76**, 6342.
- R. E. Sturgeon, X. M. Guo and Z. Mester, *Anal. Bioanal. Chem.*, 2005, **382**, 881.
- A. L. Linsebigler, G. Q. Lu and J. J. T. Yates, *Chem. Rev.*, 1995, **95**, 735.
- N. Serpone, Y. K. Ah-You, T. P. Tran, R. Harris, E. Pelizzetti and H. Hidaka, *Sol. Energy*, 1987, **39**, 491.
- A. Fujishima, T. N. Rao and D. A. Tryk, *J. Photochem. Photobiol., C*, 2000, **1**, 1.
- M. T. Litter, *Appl. Catal., B*, 1999, **23**, 89.
- J. C. Zhao, C. C. Chen and W. H. Ma, *Top. Catal.*, 2005, **35**, 269.
- Q. Q. Wang, J. Liang, J. H. Qiu and B. L. Huang, *J. Anal. At. Spectrom.*, 2004, **19**, 715.
- J. Liang, Q. Q. Wang and B. L. Huang, *Anal. Bioanal. Chem.*, 2005, **381**, 366.

- 15 Y. C. Sun, Y. C. Chang and C. K. Su, *Anal. Chem.*, 2006, **78**, 2640.
- 16 S. T. Martin, H. Herrmann and M. R. Hoffmann, *J. Chem. Soc., Faraday Trans.*, 1994, **90**, 3323.
- 17 X. F. Yin, W. Frech, E. Hoffmann, C. Ludke and J. Skole, *Fresenius' J. Anal. Chem.*, 1998, **361**, 761.
- 18 E. Ramalhosa, S. Rio Segade, E. Pereira, C. Vale and A. Duarte, *Anal. Chim. Acta*, 2001, **448**, 135.
- 19 A. I. C. Ortiz, Y. M. Albarran and C. C. Rica, *J. Anal. At. Spectrom.*, 2002, **17**, 1595.
- 20 C. Y. Wang, H. Groenzin and M. J. Shultz, *J. Am. Chem. Soc.*, 2005, **127**, 9736.
- 21 L. N. Liang, G. B. Jiang, J. F. Liu and J. T. Hu, *Anal. Chim. Acta*, 2003, **477**, 131.
- 22 C. B. Zheng, Y. Li, Y. H. He, Q. Ma and X. D. Hou, *J. Anal. At. Spectrom.*, 2005, **20**, 746.
- 23 D. L. Nunes, E. P. dos Santos, J. S. Barin, S. R. Mortari, V. L. Dressler and E. M. D. Flores, *Spectrochim. Acta, Part B*, 2005, **60**, 731.
- 24 O. Haase and J. A. C. Broekaert, *Spectrochim. Acta, Part B*, 2002, **57**, 157.
- 25 O. Haase, M. Klare, K. Krenzel-Rothensee and J. A. C. Broekaert, *Analyst*, 1998, **123**, 1219.
- 26 Y. Yamamoto, T. Kumamaru and A. Shiraki, *Fresenius' Z. Anal. Chem.*, 1978, **292**, 273.
- 27 A. de Diego, C. M. Tseng, T. Stoichev, D. Amouroux and O. F. X. Donard, *J. Anal. At. Spectrom.*, 1998, **13**, 623.
- 28 Y. W. Chen, J. Tong, A. D'Ulivo and N. Belzile, *Analyst*, 2002, **127**, 1541.
- 29 H. Haraguchi, *J. Anal. At. Spectrom.*, 2004, **19**, 5.
- 30 Y. Li, X. P. Yan and Y. Jiang, *Angew. Chem., Int. Ed.*, 2005, **44**, 6387.